

VC SERIES

Vertical Capstans

[Introduction](#) [Features](#) [Specifications](#) [Dimensions](#) [Product Codes](#)



Power and Sailing Boats

The VC Series is designed for simple, low cost anchor recovery on smaller boats and rope hauling on larger vessels.



3 YEAR
Limited Warranty



Typical stern
capstan
installation



MAXWELL

VC SERIES

Vertical Capstans

Introduction **Features** Specifications Dimensions Product Codes



FEATURES

Power and Sailing Boats

- Vertical design suits smaller powerboats or sailboats and can be utilised for anchor rodes, as a docking capstan on larger craft, or auxiliary line hauling.
- High quality finish on above deck components, hard wearing chrome over marine-grade bronze.
- Functional rope hauling from any direction using independent MAX-grip™ snag-free warping drum.
- Simplified through deck installation by modular design and precise alignment of gearbox to the top works utilising marine-grade stainless steel bolts.
- Alternative gearbox/motor positions accommodate virtually all installation situations.
- Compact, reliable gearbox, made of corrosion resistant materials.
- Anodized aluminium gearbox and spacer on 300, 500 and 1000 models.
- Heavy duty, dual direction motors, designed for marine winches.
- Easily disassembled for servicing.



STANDARD EQUIPMENT
Circuit breaker/isolator panel
Footswitch (supplied with
DC units only)

OPTIONAL EXTRAS
Traditional bronze finish
Extra deck clearance
Hydraulic motor
AutoCleave

MAXWELL

VC SERIES

Vertical Capstans

Introduction Features **Specifications** Dimensions Product Codes



SPECIFICATIONS

Power and Sailing Boats

Model	300	500	1000
Maximum Pull	136kg	227kg	455kg
	300lbs	500lbs	1000lbs
Line Speed	39m/min	18m/min	20m/min
	(Normal Working) 128ft/min	60ft/min	65ft/min
Power Supply (DC)	12 or 24V	12 or 24V	12 or 24V
Motor (Watts)	600W	600W	1000W
Net Weight (Electric)	10kg	10kg	18kg
	22lbs	22lbs	40lbs
Hydraulic Pressure	N/A	N/A	100bar
	N/A	N/A	1450psi
Hydraulic Flow	N/A	N/A	20l/min
	N/A	N/A	5.3USgal/min
Net Weight - Hyd	N/A	N/A	11kg
	N/A	N/A	24lbs



Important: Maxwell windlasses must be used in conjunction with a chain stopper and/or alternative snubbing device to take the load off the windlass while laying at anchor. The chain stopper and alternative snubbing system should also be used to secure the anchor in the fully raised position while under way.

3 YEAR
Limited Warranty

MAXWELL

VC SERIES

Vertical Capstans

Introduction Features Specifications **Dimensions** Product Codes



DIMENSIONS

Power and Sailing Boats

Model	VC300	VC500	VC1000
A	65mm 2 9/16"	65mm 2 9/16"	80mm 3 1/8"
B	106mm 4 3/16"	106mm 4 3/16"	122.5mm 4 5/6"
D (Std deck clearance)	173mm 6 7/8"	173mm 6 7/8"	252mm 9 15/16"
E	245mm 9 5/8"	245mm 9 5/8"	272mm 10 3/4"
F	132.5mm 5 7/32"	132.5mm 5 7/32"	160mm 6 5/16"
G (Std deck clearance)* or	57mm 2 1/4"	57mm 2 1/4"	100mm 4"
G (Extra deck clearance)	N/A	N/A	150mm 6"
H (Working height of drum for rope warping)	37.5mm 1 1/2"	37.5mm 1 1/2"	44mm 1 3/4"

*For VC1000 Shorter Deck Clearance version also available at 50mm (2")

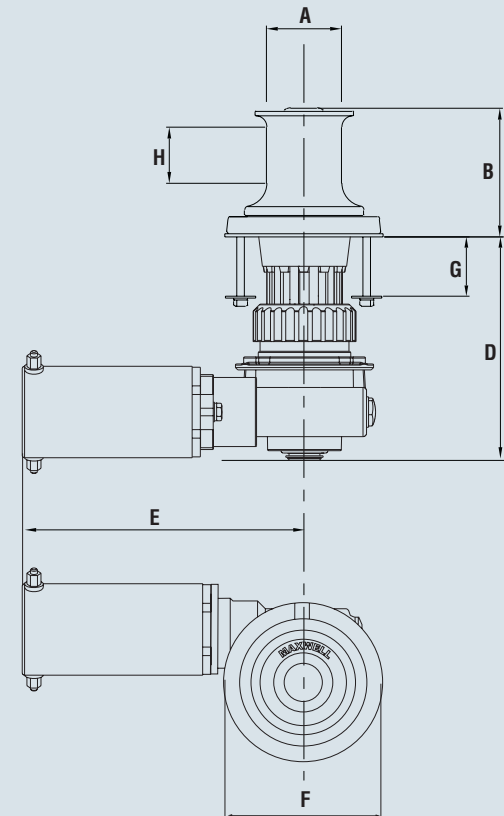

Important: Maxwell windlasses must be used in conjunction with a chain stopper or snubbing device to take the load off the windlass while laying at anchor. The chain stopper and alternative snubbing system should also be used to secure the anchor in the fully raised position while under way.

3 YEAR
Limited Warranty

MAXWELL

VC SERIES

Vertical Capstans

[Introduction](#) [Features](#) [Specifications](#) [Dimensions](#) [Product Codes](#)



PRODUCT CODES

Power and Sailing Boats

Product code	Model
P100453	VC 300 Fast 12 Volt
P100454	VC 300 Fast 24 Volt
P100455	VC 500 12 Volt
P100456	VC 500 24 Volt
P102787	VC 1000 12 Volt
P102788	VC 1000 24 Volt

3 YEAR
Limited Warranty

MAXWELL