

HWC SERIES

Horizontal Windlass and Capstan

[Introduction](#) [Features](#) [Specifications](#) [Dimensions](#) [Product Codes](#)



Power and Sailing Boats

The HWC Series is designed for automatic horizontal handling of chain only anchor rodes while offering an independent capstan for the retrieval of a secondary rope and chain rode or to assist with docking procedures.



3 YEAR
Limited Warranty

MAXWELL

HWC SERIES

Horizontal Windlass and Capstan

Introduction **Features** Specifications Dimensions Product Codes

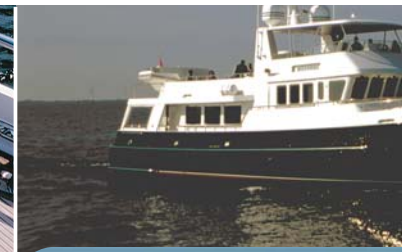

FEATURES

Power and Sailing Boats

- Fully automatic single or dual direction chainwheel operation.
- Functional rope hauling from fore and aft using independent MAX-grip™ snag-free warping drum with clutch disengagement of chainwheel for positive control of all ropes.
- Optional dual anchor handling with smooth independent control of each chainwheel via cone clutches.
- Chainpipe assembly supplied.
- Cone-type clutch/brake mechanism permits manual free-fall anchoring.
- Cone clutches, unlike dog clutches, provide smooth progressive engagement ensuring safe and precise operator control.
- Chainwheel locking pawl to assist when using warping drum independently.
- Simple deck mounted installation with no under deck parts.
- Simplified maintenance with ability to strip the running gear (chainwheel and drum) from the windlass without disturbing the windlass mounting.
- Heavy duty, dual direction motor, designed for marine winches.
- Chainwheel and warping drum of high-quality chrome finish over marine-grade bronze.
- Marine-grade alloy casing pretreated, powder coated and finished with a two component white polyurethane paint.



STANDARD EQUIPMENT

Circuit breaker/isolator panel
Footswitch (supplied with DC units only)
Chainpipe and chainwheel
Emergency crank/clutch release handle

OPTIONAL EXTRAS

Dual direction solenoid pack
Traditional bronze finish (chainwheel & capstan)
Vertical warping drum featuring MAX-grip™ for independent rope hauling from any direction (HWVC3500 only)

Up/down remote control panel
Hydraulic motor
Chain Stopper
AutoAnchor™ Rode Counter
AutoCleave
Chain snubber

MAXWELL

HWVC SERIES

Horizontal Windlass and Capstan

Introduction Features **Specifications** Dimensions Product Codes



Power and Sailing Boats

SPECIFICATIONS

MODEL	1500	2200	3500	HWVC3500
Maximum Pull	680kg	1000kg	1590kg	1590kg
	1500lbs	2200lbs	3500lbs	3500lbs
Chain Sizes (Short Link)	6-10mm 1/4" - 3/8"	9-11mm 5/16" - 3/8"	10-13mm 3/8" - 1/2"	10-13mm 3/8" - 1/2"
	Line Speed (Normal Working)	17m/min 56ft/min	17m/min 56ft/min	10m/min 33ft/min
Power Supply (DC)	12 or 24V	12 or 24V	12 or 24V	12 or 24V
Motor (Power)	1200W	1200W	1200W	1200W
Net Weight - DC	24kg 52lbs	55kg 121lbs	57kg 125lbs	94.5kg 208lbs
	Hydraulic Pressure	138bar 2000psi	135bar 1950psi	138bar 2000psi
Hydraulic Flow	20 l/min 5.3 USgal/min	36 l/min 9.5 USgal/min	40 l/min 11 USgal/min	40 l/min 11 USgal/min
	Net Weight - Hyd	17kg 37lbs	48.5kg 107lbs	49kg 107lbs



Important: Maxwell windlasses must be used in conjunction with a chain stopper and/or alternative snubbing device to take the load off the windlass while laying at anchor. The chain stopper and alternative snubbing system should also be used to secure the anchor in the fully raised position while under way.

3 YEAR
Limited Warranty

MAXWELL

HWC SERIES

Horizontal Windlass and Capstan

Introduction Features Specifications **Dimensions** Product Codes



Power and Sailing Boats

DIMENSIONS

MODEL	1500	2200	3500	HWVC3500
A	390mm 15 3/8"	495mm 19 1/2"	515mm 20 9/32"	515mm 20 9/32"
B	205mm 8 1/16"	289mm 11 3/8"	316mm 12 7/16"	446mm 17 9/16"
C	382mm 15"	516mm 20 5/16"	549mm 21 5/8"	710mm 28"
D (Hole centres)	210mm 8 9/32"	234mm 9 1/4"	260mm 10 1/4"	417mm 18 7/16"
F (Hole centres)	225mm 8 7/8"	278mm 10 15/16"	308mm 12 1/8"	464mm 18 1/4"
G (Approximate hole centres)	260mm 10 1/4"	300mm 11 13/16"	348mm 13 11/16"	348mm 13 11/16"
H (Working height of drum for rope warping)	44mm 1 3/4"	60mm 2 3/8"	53mm 2 3/32"	53mm 2 3/32"
I	95mm 3 3/4"	125mm 4 15/16"	130mm 5 1/8"	130mm 5 1/8"
J	151mm 5 15/16"	194mm 7 5/8"	208mm 8 3/16"	287mm 11 19/64"

HWC

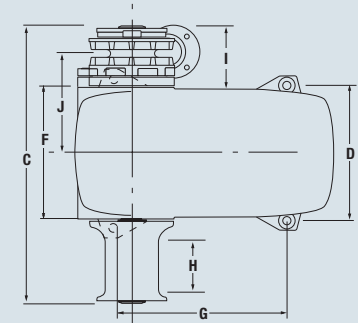
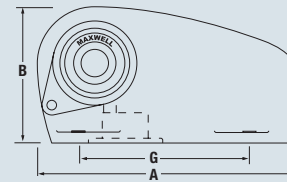

HWVC

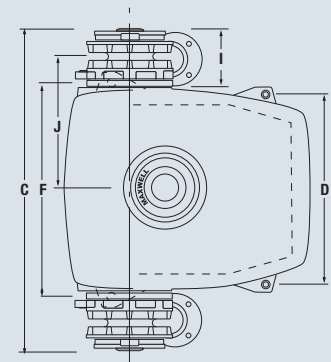
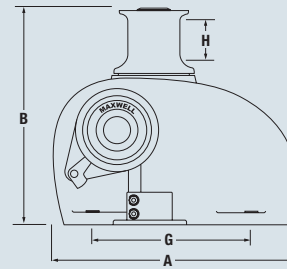

Important: Maxwell windlasses must be used in conjunction with a chain stopper and/or alternative snubbing device to take the load off the windlass while laying at anchor. The chain stopper and alternative snubbing system should also be used to secure the anchor in the fully raised position while under way.

3YEAR
Limited Warranty

MAXWELL

HWC SERIES

Horizontal Windlass and Capstan

Introduction Features Specifications Dimensions **Product Codes**



Power and Sailing Boats

PRODUCT CODES

Product code	Model
P100231	HWC 1500 (Capstan port, chain wheel starboard) 12 Volt
P100232	HWC 1500 (Capstan port, chain wheel starboard) 24 Volt
P13083	HWC 2200 (Capstan port, chain wheel starboard) 12 Volt
P13090	HWC 3500 (Double chain wheel) 24 Volt
P13093	HWC 3500 (Capstan port, chain wheel starboard) 12 Volt
P13094	HWC 3500 (Capstan port, chain wheel starboard) 24 Volt
P14292	HWC 3500 (Capstan port, chain wheel starboard) Hydraulic
P13102	HWVC 3500 (Capstan port, chain wheel starboard vertical capstan) 24 Volt
P14289	HWVC 3500 (Chain wheel port, chain wheel starboard vertical capstan) Hydraulic

3 YEAR
Limited Warranty

MAXWELL