

HRC

Rope/Chain Series

[Introduction](#) [Features](#) [Specifications](#) [Product Codes](#)



Power and Sailing Boats

The compact HRC-6 and HRC-8 are Maxwell's horizontal versions of the renowned Freedom 500 and 800 vertical rope/chain windlasses. The HRC-6 and HRC-8 are packed with new and proven features including the patented rode management technology developed for the Freedom.

Proven top performance in an independent test, the HRC will provide years of reliable use and customer satisfaction.



3 YEAR
Limited Warranty

MAXWELL

HRC

Rope/Chain Series

Introduction **Features** Specifications Product Codes



FEATURES

Power and Sailing Boats

- Aesthetically pleasing above deck design, encapsulating the motor and drive in an IP66 rated watertight case, saving space below deck and allowing simple routine maintenance.
- High-pressure die cast, marine-grade, alloy case is chromate passivated and polyester powder coated for unsurpassed marine protection.
- Simple “bolt down” installation ensures effortless and rapid on-deck installation and set up.
- Proven and patented pressure arm system, within a safe, enclosed design, guarantees trouble free rode transition from rope to chain.
- Integrated composite nylon, through deck hawse pipe for ease of installation and smooth, snag free operation.
- High efficiency spur gearbox incorporating a robust non-backwind mechanism.
- High speed, jam free retrieval of rope and chain controlled from a remote panel mounted Up/down switch.
- Emergency free-fall function in the event of onboard power failure.
- High quality chrome finished and innovative chainwheels, constructed of marine-grade bronze, are suitable for use with 6 to 8mm (1/4” to 5/16”) short link chain and either 3 strand or 8 plait rope.
- Heavy duty, dual direction motor incorporating “new technology” features, including integrated wiring for quick electrical installation, is easily removed for simple routine electric brush maintenance.
- Trouble free transition from rope to chain by means of an innovative pressure arm system within a safer enclosed design.



3 YEAR
Limited Warranty

STANDARD EQUIPMENT

Up/down remote control panel
Dual direction control system
Circuit breaker/isolator panel
Emergency free fall activation lever

OPTIONAL EXTRAS

AutoAnchor™ Rode Counter
Footswitches
AutoCleave
Chain stopper
Chain snubber

MAXWELL

HRC

Rope/Chain Series

Introduction Features **Specifications** Product Codes



Power and Sailing Boats

SPECIFICATIONS

Model	HRC-6	HRC-8
Maximum Pull	270kg 600lbs	405kg 900lbs
Chain Short Link	6mm/7mm 1/4"	8mm 5/16"
Rope Size (Nylon)* 3 strand or 8 plait (8 plait recommended)	12mm 1/2"	14mm 9/16"
Line Speed (Anchor Retrieval) Nominal 30kg working load	25m/min 81ft/min	33m/min 108ft/min
Power Supply (DC)	12V	12V/24V
Motor Power	400W	600W
Net Weight	11kg 24lbs	11.5kg 25lbs
Circuit Breaker	50Amp	70Amp

* refer to owners manual for rope size variations.

DIMENSIONS

	BOTH MODELS	
	mm	inches
A	260mm	10 1/4"
B	150mm	5 29/32"
C	197mm	7 3/4"
D	120mm	4 23/32"
E	250mm	9 7/8"
F	77mm	3 1/16"

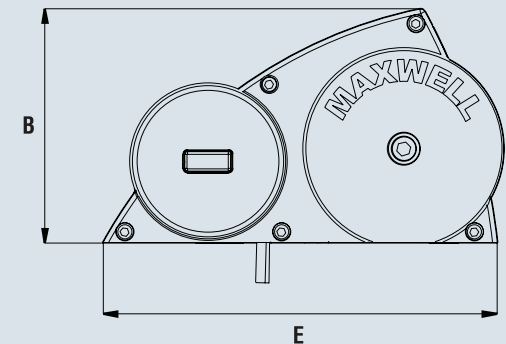
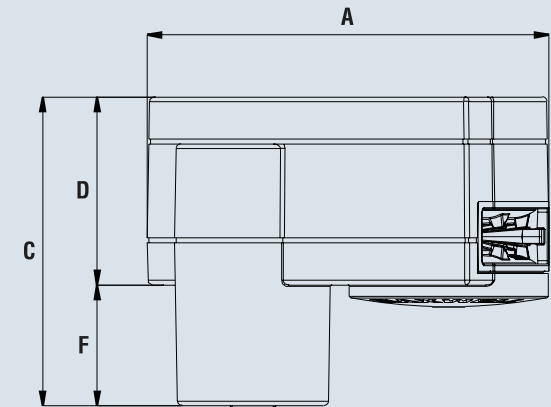
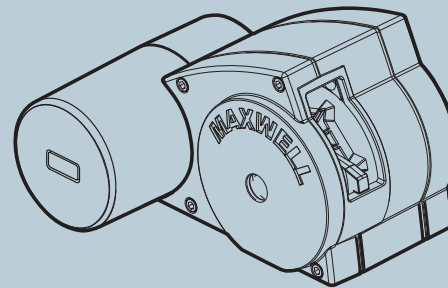

Important: Maxwell windlasses must be used in conjunction with a chain stopper and/or alternative snubbing device to take the load off the windlass while laying at anchor. The chain stopper and alternative snubbing system should also be used to secure the anchor in the fully raised position while under way.

3 YEAR
Limited Warranty

MAXWELL

HRC

Rope/Chain Series

Introduction Features Specifications **Product Codes**



Power and Sailing Boats

PRODUCT CODES

Product code	Model
P102801	HRC 6 (for 6mm chain spliced to 12mm line) 12 Volt
P102803	HRC 6 (for 6mm chain spliced to 12mm line) 24 Volt
P102802	HRC 6 (for 7mm/1/4" chain spliced to 12mm/1/2" line) 12 Volt
P102804	HRC 6 (for 7mm/1/4" chain spliced to 12mm/1/2" line) 24 Volt
P102807	HRC 8 (for 8mm/5/16" chain spliced to 14mm/9/16" line) 12 Volt
P102811	HRC 8 (for 8mm/5/16" chain spliced to 14mm/9/16" line) 24 Volt

Recommended Accessories



3 YEAR
Limited Warranty

MAXWELL