

Freedom

Rope/Chain Series

[Introduction](#) [Features](#) [Specifications](#) [Product Codes](#)



Power and Sailing Boats

The Freedom Series of automatic rope/chain windlasses incorporate Maxwell's design technology for rope to chain spliced rodes.

Freedom's unique, compact design and elegant styling, has made it the primary choice of both boat builders and boat owners around the world. An independent test report rates Freedom as the number one automatic rope/chain windlass in its class.



3 YEAR
Limited Warranty

MAXWELL

Freedom

Rope/Chain Series

Introduction **Features** Specifications Product Codes



FEATURES

Power and Sailing Boats

- Maxwell's revolutionary design automatically feeds anchor rode into and out of the anchor locker allowing effortless handling of rope/chain rodes.
- Sleek, captive on deck design for smooth, snag free operation.
- Maxwell's unique performance plate (supplied with winch), in combination with the use of 8 plait nylon rope, will ensure trouble free performance.
- High speed, jam free retrieval of rope and chain from remote control stations.
- Dual direction, power up and down operation.
- Cone type clutch/brake mechanism permits manual "free fall" anchoring. A cone clutch, unlike a dog clutch provides smooth disengagement of the chainwheel.
- Simplified modular installation without disassembly of windlass.
- Alternative gearbox/motor positions accommodate virtually all installation situations.
- Manual override using the emergency crank handle provided.
- Marine-grade, hard anodised alloy housing finished in metallic charcoal.
- Full disassembly capability of topworks utilising handle provided and a screwdriver – no special tools required.
- Heavy duty, dual direction motor, designed for marine winches, isolated ground type, with durable class F insulation. Easily removed for servicing.
- Sealed oil bath and marine-grade anodised alloy gearbox provides a robust output drive via precision worm and wormwheel.
- Trouble free transition from rope to chain by means of an innovative pressure arm system within a safer enclosed design.

Freedom with
Capstan



Freedom RC500



3 YEAR
Limited Warranty

STANDARD EQUIPMENT

Circuit breaker/isolator panel
Dual direction solenoid pack
Up/down remote control panel
Performance plate
Emergency crank/clutch release handle

OPTIONAL EXTRAS

Extra deck clearance kit
Capstan model
Auto Anchor™ Rode Counter
Foot switch
AutoCleave
Chain stopper
Chain snubber

MAXWELL

Freedom

Rope/Chain Series

Introduction Features **Specifications** Product Codes



Power and Sailing Boats

SPECIFICATIONS

Model	RC500	RC800
Maximum Pull	227kg 500lbs	364kg 800lbs
Chain Short Link	6mm/7mm 1/4"	8mm 5/16"
Rope Size (Nylon)*	12mm 3 strand or 8 plait (8 plait recommended) 1/2"	14mm 9/16" – 5/8"
Chain Speed (Normal Working)	19m/min 62ft/min	33m/min 108ft/min
Rope Speed (Normal Working)	14m/min 45ft/min	21m/min 69ft/min
Power Supply (DC)	12 or 24V	12 or 24V
Motor (Watts)	600W	1000W
Net Weight	12.5kg 27.5lbs	16.5kg 36.3lbs

* refer to owners manual for rope size variations.

DIMENSIONS

Model	RC500	RC800
A	207mm 8 3/16"	207mm 8 3/16"
B1	79mm 3 1/8"	79mm 3 1/8"
B2 (With capstan)	145mm 5 3/4"	145mm 5 3/4"
C	168mm 6 11/16"	168mm 6 11/16"
D (Std deck clearance)	193mm 7 9/16"	215mm 8 7/16"
E	364mm 14 3/8"	396mm 15 5/8"
F	240mm 9 7/16"	272mm 10 3/4"
G (Std deck clearance)	65mm 2 1/2"	65mm 2 1/2"
G (Extra deck clearance)	165mm 6 1/2"	165mm 6 1/2"

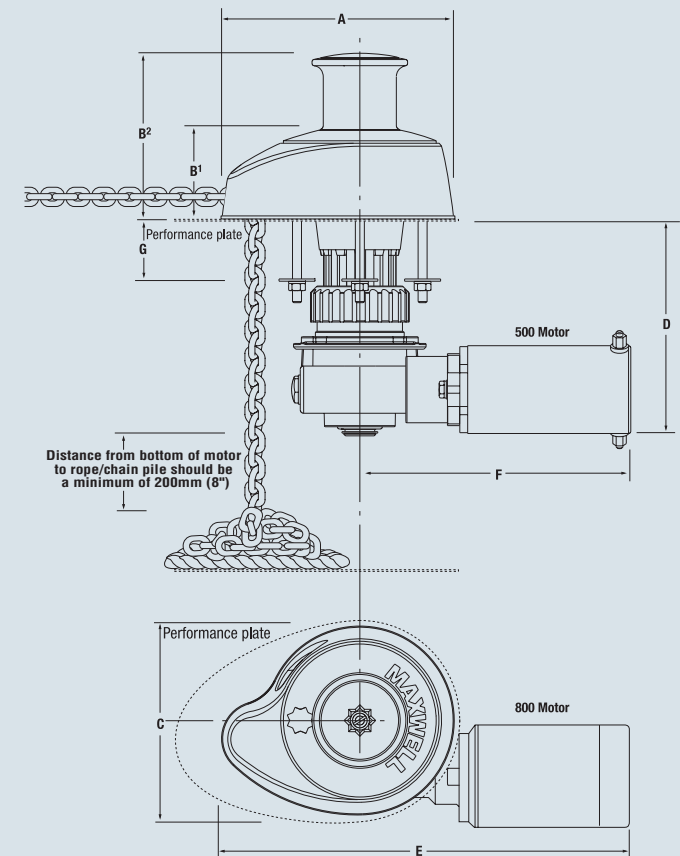

Important: Maxwell windlasses must be used in conjunction with a chain stopper and/or alternative snubbing device to take the load off the windlass while laying at anchor. The chain stopper and alternative snubbing system should also be used to secure the anchor in the fully raised position while under way.

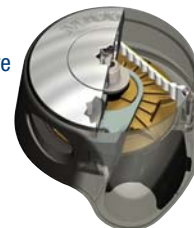

3 YEAR
Limited Warranty

MAXWELL

Freedom

Rope/Chain Series

Introduction Features Specifications **Product Codes**



Power and Sailing Boats

PRODUCT CODES

Product code	Model
P100000	Freedom RC 500 (for 1/4" HT chain spliced to 1/2" line) 12 Volt
P100010	Freedom RC 500 (for 6mm HT chain spliced to 12mm line) 12 Volt
P100014	Freedom RC 500 with Capstan (for 6mm HT chain spliced to 12mm line) 12 Volt
P100001	Freedom RC 800 (for 5/16" HT chain spliced to 5/8" line) 12 Volt
P100011	Freedom RC 800 (for 8mm HT chain spliced to 14mm line) 12 Volt
P100015	Freedom RC 800 with Capstan (for 8mm HT chain spliced to 14mm line) 12 Volt

Recommended Accessories



3 YEAR
Limited Warranty

MAXWELL